

FX2NC-1HC

USER'S MANUAL



Manual Number	JY997D30701
Revision	C
Date	April 2015

This manual describes the part names, dimensions, mounting, wiring, and specifications of the product. Before use, read this manual and the manuals of all relevant products fully to acquire proficiency in handling and operating the product. Make sure to learn all the product information, safety information, and precautions.

Store this manual in a safe place so that it can be taken out and read whenever necessary. Always forward it to the end user.

Registration:

The company and product names described in this manual are registered trademarks or the trademarks of their respective companies.

Effective April 2015

Specifications are subject to change without notice.

© 2007 Mitsubishi Electric Corporation

Safety Precaution (Read these precautions before use.)

This manual classifies the safety precautions into two categories:

and .

	Indicates that incorrect handling may cause hazardous conditions, resulting in death or severe injury.
	Indicates that incorrect handling may cause hazardous conditions, resulting in medium or slight personal injury or physical damage.

Depending on the circumstances, procedures indicated by may also cause severe injury.

It is important to follow all precautions for personal safety.

Associated Manuals

Manual name	Manual No.	Description
FX3UC Series User's Manual - Hardware Edition	JY997D28701 MODEL CODE: 09R519	Explains the FX3UC Series PLC specifications for I/O, wiring, installation, and maintenance.
FX3S/FX3G/FX3GC/FX3U/FX3UC Series Programming Manual - Basic & Applied Instruction Edition	JY997D16601 MODEL CODE: 09R517	Describes PLC programming for basic/applied instructions and devices.
FX2NC (DSS/DS) Series Hardware Manual	JY992D76401 MODEL CODE: 09R509	Explains the FX2NC (DSS/DS) Series PLC specifications for I/O, wiring, installation, and maintenance.
FX2NC (D/UL) Series Hardware Manual	JY992D87201	Explains the FX2NC (D/UL) Series PLC specifications for I/O, wiring, installation, and maintenance.
FX Series Programming Manual II	JY992D88101 MODEL CODE: 09R512	Describes FX1S/FX1N/FX2N/FX2NC Series PLC programming for basic/applied instructions and devices.

How to obtain manuals

For product manuals or documents, consult with the Mitsubishi Electric dealer from who you purchased your product.

Certification of UL, cUL standards

The following product has UL and cUL certification.

UL, cUL File Number: E95239

Models: MELSEC FX2NC series manufactured from December 1st, 2007 FX2NC-1HC

Compliance with EC directive (CE Marking)

This note does not guarantee that an entire mechanical module produced in accordance with the contents of this note will comply with the following standards. Compliance to EMC directive and LVD directive for the entire mechanical module should be checked by the user / manufacturer. For more details please contact the local Mitsubishi Electric sales site.

Requirement for Compliance with EMC directive

The following products have shown compliance through direct testing (of the identified standards below) and design analysis (through the creation of a technical construction file) to the European Directive for Electromagnetic Compatibility (2004/108/EC) when used as directed by the appropriate documentation.

Attention

- This product is designed for use in industrial applications.

Note

- Authorized Representative in the European Community:
Mitsubishi Electric Europe B.V.
Gothaer Str. 8, 40880 Ratingen, Germany

Type: Programmable Controller (Open Type Equipment)

Models: MELSEC FX2nc series manufactured from December 1st, 2007 FX2NC-1HC

Standard	Remark
EN61000-6-4:2007 Electromagnetic compatibility - Generic standards - Emission standard for industrial environment	Compliance with all relevant aspects of the standard. (Radiated Emissions and Mains Terminal Voltage Emissions)
EN61000-6-2:2005 Electromagnetic compatibility - Generic immunity standard Industrial environment	Compliance with all relevant aspects of the standard. (RF Immunity, Fast Transients, ESD, Conducted, Surges, Power Magnetic Fields, Voltage dips and Voltage interruptions)
EN61131-2:2007 Programmable controllers - Equipment requirements and tests	Compliance with all relevant aspects of the standard. EMI • Radiated Emissions • Conducted Emissions EMS • Radiated electromagnetic field • Fast transient burst • Electrostatic discharge • High-energy surge • Voltage drops and interruptions • Conducted RF • Power frequency magnetic field

1. Outline

The hardware high-speed counter block is a 2-phase 50 kHz high-speed counter. It is a special function block for the FX2NC, FX3UC series PLC.

- FROM/TO instruction transfers the PLC data (i.e. parameters, comparing value and present value).
- The FX2NC-1HC occupies 8 points of I/O on the FX2NC, FX3UC expansion bus. The 8 points can be allocated from either inputs or outputs. However, 5V DC 90mA power is supplied from the main unit or extension power supply units. There must be no power overload from this or any other extension unit. Furthermore, another power supply is needed for the output circuit of the encoder or the transistor.
- Differential-Line-Driver (AM26C31 or equivalent) and open collector output encoders are available for FX2NC-1HC.
- The source of your input signal should be a 1 or 2 phase encoder. A 5V, 12V, or 24V power source can be used. An initial value setting command input (PRESET) and a count prohibit command input (DISABLE) are also available.
- The FX2NC-1HC has two outputs. When the counter value coincides with an output compare value, the appropriate output is set ON. The output transistors are individually isolated to allow either sink or source connection methods.
- Various counter modes, such as 1-phase or 2-phase, 16-bit or 32-bit modes, can be selected using commands from the PLC. Allow the FX2NC-1HC unit to run only after setting these mode parameters.

1.1 Incorporated Items

Verify that the following product and items are included in the package:

Included Items	
FX2NC-1HC	1 Unit
Special unit/block No. label	1 Sheet
Manuals [Japanese version, English version]	1 manual each

1.2 External Dimensions, Part Names, and Terminal Layout

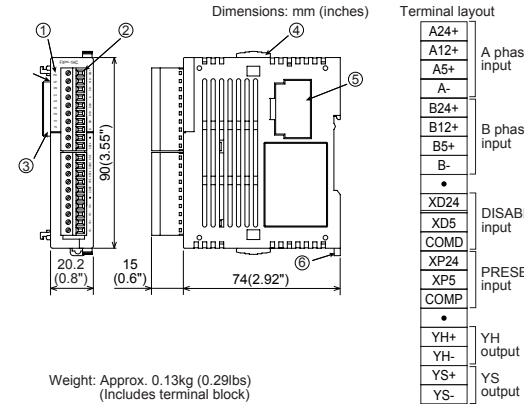

No.	Name	
①	Status LED	
	PW (Green)	Power LED ON when the 5V power supply is normally supplied from the PLC.
	UP (Red)	Up count LED
	DN (Red)	Down count LED
	φA	A phase input
	φB	B phase input
	DS	DISABLE input LED
	PR	PRESET input LED
	YH	YH output LED
	YS	YS output LED
②	Terminal block (European type)	
③	Extension connector (PLC side) Used to connect this special function block to the FX2NC, FX3UC main unit or extension block.	
④	Slide lock Used to fix the FX2NC extension block on the right side of this special function block.	
⑤	Extension connector (Extension side) Used to connect the FX2NC extension block to the right of this special function block. Remove this cover for connecting.	
⑥	DIN rail mounting hook	

2. Installation, Connect to the PLC

INSTALLATION PRECAUTIONS	
<ul style="list-style-type: none"> Make sure to cut off all phases of the power supply externally before attempting installation or wiring work. Failure to do so may cause electric shock or damage to the product. 	

INSTALLATION PRECAUTIONS	
<ul style="list-style-type: none"> Use the product within the generic environment specifications described in PLC main unit manual. Never use the product in areas with excessive dust, oily smoke, conductive dusts, corrosive gas (salt air, Cl₂, H₂S, SO₂, or NO₂), flammable gas, vibration or impacts, or expose it to high temperature, condensation, or rain and wind. If the product is used in such conditions, electric shock, fire, malfunctions, deterioration or damage may occur. When drilling screw holes or wiring, make sure cutting or wire debris does not enter the ventilation slits. Failure to do so may cause fire, equipment failures or malfunctions. Connect FX2NC-1HC securely to their designated connectors. Loose connections may cause malfunctions. Use screwdrivers carefully when performing installation work, thus avoiding accident or product damage. 	

2.1 Installation

The FX2NC-1HC can be installed on a DIN46277 rail (35 mm (1.38") wide).

2.2 Number of the connectable units

- FX2NC PLC
Up to four special function units/blocks in total can be connected to the FX2NC Series PLC including those connected to the FX2NC-CNV-IF.
- FX3UC PLC
Up to eight special function units/blocks in total can be connected to the FX3UC¹ Series PLC including those connected to the FX2NC-CNV-IF or FX3UC-1PS-5V.

¹ Up to seven special function units/blocks in total can be connected to the FX3UC-32MT-LT(-2) PLC. Unit numbers assigned to special function units/blocks begins with No.1.

2.3 Connection to the PLC

When connecting the FX2NC-1HC to the FX2NC / FX3UC Series main unit or extension block, remove the extension port cover from the right side of the main unit or extension block, keep the slide lock in the main unit or extension block pulled upward, then align the hook in the FX2NC-1HC with the mounting hole in the former step of the main unit or extension block.

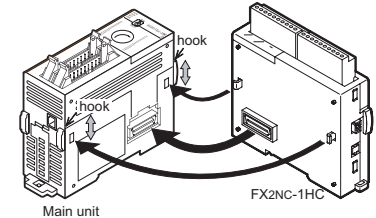

Then push the slide lock downward to fix the FX2NC-1HC. When connecting two or more FX2NC-1HC units, connect an FX2NC-1HC unit to another FX2NC-1HC unit in the same way.

3. Wiring

WIRING PRECAUTIONS	
<ul style="list-style-type: none"> Make sure to cut off all phases of the power supply externally before attempting installation or wiring work. Failure to do so may cause electric shock or damage to the product. 	

WIRING PRECAUTIONS	
<ul style="list-style-type: none"> Make sure to cut off all phases of the power supply externally before attempting installation or wiring work. Failure to do so may cause electric shock or damage to the product. 	

WIRING PRECAUTIONS **CAUTION**

- Make sure to observe the following precautions in order to prevent any damage to the machinery or accidents due to abnormal data written to the PLC under the influence of noise:
 - Do not bundle the main circuit line together with or lay it close to the main circuit, high-voltage line or load line. Otherwise, noise disturbance and/or surge induction are likely to take place. As a guideline, lay the control line at least 100mm (3.94") or more away from the main circuit or high-voltage lines.
 - Ground the shield wire or shield of the shielded cable at one point on the PLC. However, do not use common grounding with heavy electrical systems.
- Make sure to properly wire to the terminal board (European type) in accordance with the following precautions. Failure to do so may cause electric shock, equipment failures, a short-circuit, wire breakage, malfunctions, or damage to the product.
 - The disposal size of the cable end should follow the dimensions described in the manual.
 - Tightening torque should follow the specifications in the manual.
 - Twist the end of strand wire and make sure that there are no loose wires.
 - Do not solder-plate the electric wire ends.
 - Do not connect more than the specified number of wires or electric wires of unspecified size.
 - Affix the electric wires so that neither the terminal block nor the connected parts are directly stressed.

3.1 Wire and Terminal Tightening Torque

3.1.1 Cable

1) Applicable cable

Type	Wire size
Single wire	0.3mm ² to 0.5mm ² (AWG22 to 20)
Double wire	0.3mm ² (AWG22)*2

2) Termination

Strip the coating of strand wire and twist the cable core before connecting it, or strip the coating of single wire before connecting it. An alternative connection is to use a ferrule with insulating sleeve.

Manufacturer	Model	Pressure bonding tool
Phoenix Contact	Al 0.5-8WH	CRIMPFOX 6 ¹ (or CRIMPFOX 6T-F ²)

*1 Old model name: CRIMPFOX ZA 3

*2 Old model name: CRIMPFOX UD 6

- Stranded wire/solid wire
- Bar terminal with insulating sleeve

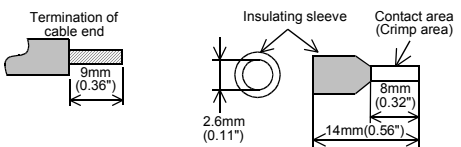

When using a stick terminal with an insulating sleeve, choose a wire with proper cable sheath referring to the above outside dimensions, otherwise the wire cannot be inserted easily.

3.1.2 Tightening Torque

The tightening torque must be 0.22 to 0.25N-m. Do not tighten terminal screws exceeding the specified torque. Failure to do so may cause equipment failures or malfunctions.

Tool

To tighten terminals, use a purchased small-sized screwdriver whose head is straight and is not widened as shown in the right figure.

Note: If the diameter of screwdriver grip is too small, tightening torque will not be able to be achieved. Use the following recommended screwdriver or an appropriate replacement (grip diameter: approximately 25mm).

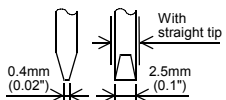

Manufacturer	Model
Phoenix Contact	SZS 0.4X2.5

3.2 Wiring

Note: Make sure to properly wire in accordance with the encoder output specifications. Incorrect wiring may cause accidents or damage to the product.

3.2.1 NPN output encoders

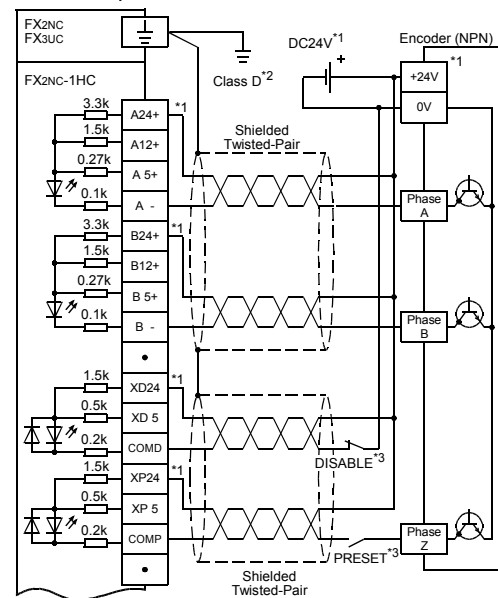

- *1. Drive power supply of the encoder. Use either 24V DC, 12V DC, or 5V DC according to the encoder type. When connecting the A phase, the B phase, and the Z phase to FX2NC-1HC, connect to the power supply terminal. When using 24V DC for PRESET and DISABLE signals, connect to the 24V DC (XP24, XD24) terminal.
- *2. Grounding resistance 100 Ω or less.
- *3. This wiring is unnecessary when not using the PRESET function and the DISABLE function.

3.2.2 PNP output encoders

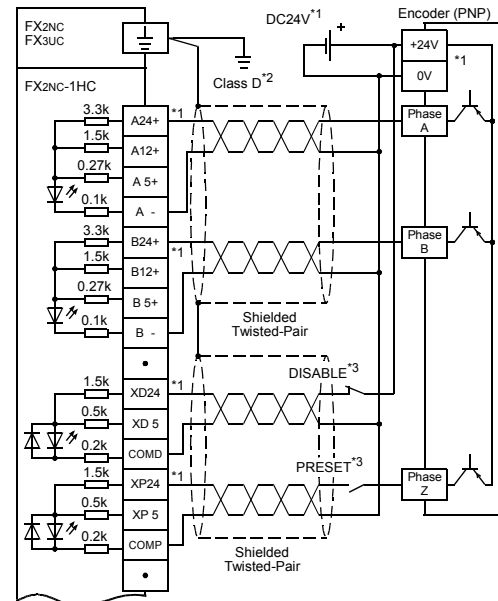

- *1. Drive power supply of the encoder. Use either 24V DC, 12V DC, or 5V DC according to the encoder type. When connecting the A phase, the B phase, and the Z phase to FX2NC-1HC, connect to the power supply terminal. When using 24V DC for PRESET and DISABLE signals, connect to the 24V DC (XP24, XD24) terminal.
- *2. Grounding resistance 100 Ω or less.
- *3. This wiring is unnecessary when not using the PRESET function and the DISABLE function.

3.2.3 Differential-Line-Driver output encoders

When applying the Differential-Line-Driver encoder (AM26C31 or equivalent) to FX2NC-1HC, connect the encoder output with the 5V DC terminal as shown in the left figure.

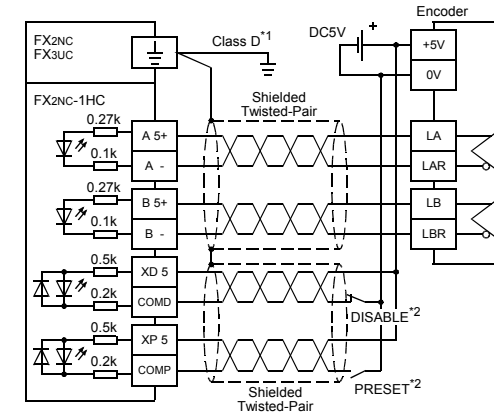

- *1. Grounding resistance 100 Ω or less.
- *2. This wiring is unnecessary when not using the PRESET function and the DISABLE function.

3.2.4 YH, YS output wiring [Sink wiring]

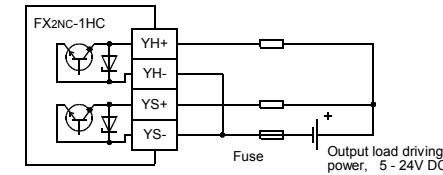

3.2.5 YH, YS output wiring [Source wiring]

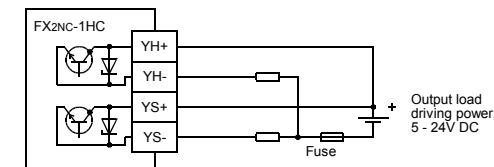

4. Specifications

DESIGN PRECAUTIONS **WARNING**

- Make sure to have the following safety circuits outside of the PLC to ensure safe system operation even during external power supply problems or PLC failure. Otherwise, malfunctions may cause serious accidents.
 - Most importantly, have the following: an emergency stop circuit, a protection circuit, an interlock circuit for opposite movements (such as normal vs. reverse rotation), and an interlock circuit (to prevent damage to the equipment at the upper and lower positioning limits).
 - Note that when the PLC CPU detects an error, such as a watchdog timer error, during self-diagnosis, all outputs are turned off. Also, when an error that cannot be detected by the PLC CPU occurs in an input/output control block, output control may be disabled. External circuits and mechanisms should be designed to ensure safe machinery operation in such a case.
 - Note that when an error occurs in a relay, triac or transistor output device, the output could be held either on or off. For output signals that may lead to serious accidents, external circuits and mechanisms should be designed to ensure safe machinery operation in such a case.

DESIGN PRECAUTIONS **CAUTION**

- Do not bundle the control line together with or lay it close to the main circuit or power line. As a guideline, lay the control line at least 100mm (3.94") or more away from the main circuit or power line. Noise may cause malfunctions.

4.1 General Specifications

The general specifications are equivalent to the PLC main unit. (For general specifications, refer to the manual of the PLC main unit.)

4.2 Power Supply Specifications

Item	Specifications
Units driving power	5V DC, 90mA (Internal power supply from main unit or extension power supply unit)

4.3 Performance Specifications

Item	Specification									
Input signal	Signal level (Selected by terminal connection) <table border="1"> <tr> <td>Phase A, Phase B</td> <td>[A24+], [B24+]</td> <td>24V DC±10%, 7mA or less</td> </tr> <tr> <td></td> <td>[A12+], [B12+]</td> <td>12V DC±10%, 7mA or less</td> </tr> <tr> <td></td> <td>[A5+], [B5+]</td> <td>3.0V to 5.5V DC, 12.5mA or less</td> </tr> </table>	Phase A, Phase B	[A24+], [B24+]	24V DC±10%, 7mA or less		[A12+], [B12+]	12V DC±10%, 7mA or less		[A5+], [B5+]	3.0V to 5.5V DC, 12.5mA or less
	Phase A, Phase B	[A24+], [B24+]	24V DC±10%, 7mA or less							
	[A12+], [B12+]	12V DC±10%, 7mA or less								
	[A5+], [B5+]	3.0V to 5.5V DC, 12.5mA or less								
	PRESET, DISABLE <table border="1"> <tr> <td></td> <td>[XP24], [XD24]</td> <td>10.8V to 26.4V DC, 15mA or less</td> </tr> <tr> <td></td> <td>[XP5], [XD5]</td> <td>5V DC±10%, 8mA or less</td> </tr> </table>		[XP24], [XD24]	10.8V to 26.4V DC, 15mA or less		[XP5], [XD5]	5V DC±10%, 8mA or less			
	[XP24], [XD24]	10.8V to 26.4V DC, 15mA or less								
	[XP5], [XD5]	5V DC±10%, 8mA or less								
MAX. frequency	1-phase input <table border="1"> <tr> <td>1 input</td> <td>1 input</td> </tr> <tr> <td>2 input</td> <td>50kHz</td> </tr> </table>	1 input	1 input	2 input	50kHz					
	1 input	1 input								
2 input	50kHz									
	2-phase input <table border="1"> <tr> <td>1 edge count</td> <td>1 edge count</td> </tr> <tr> <td>2 edge count</td> <td>25kHz</td> </tr> <tr> <td>4 edge count</td> <td>12.5kHz</td> </tr> </table>	1 edge count	1 edge count	2 edge count	25kHz	4 edge count	12.5kHz			
1 edge count	1 edge count									
2 edge count	25kHz									
4 edge count	12.5kHz									
Pulse shape										
	t1(Rise/fall time): 3µs or less t2(ON/OFF pulse): 6µs or more (at 50kHz) t3(Phase difference between A and B): 3.5µs or more (at 50kHz) PRESET(Z phase) input: 100µs or more DISABLE (count prohibit) input: 100µs or more									
Format	Automatic UP/DOWN However, when on 1-phase 1-input mode, UP/DOWN is determined below. <ul style="list-style-type: none"> Hardware UP/DOWN: Up/down count is decided by OFF/ON of the A-phase input terminal. Software UP/DOWN: Up/down count is decided by the current value (K0/K1) of BFM #1. 									
Counting specification	Range <table border="1"> <tr> <td>When 32-bit is specified:</td> <td>-2,147,483,648 to +2,147,483,647</td> </tr> <tr> <td>When 16-bit is specified:</td> <td>0 to 65,535 (upper limit is set up by BFM #3, #2.)</td> </tr> </table>	When 32-bit is specified:	-2,147,483,648 to +2,147,483,647	When 16-bit is specified:	0 to 65,535 (upper limit is set up by BFM #3, #2.)					
When 32-bit is specified:	-2,147,483,648 to +2,147,483,647									
When 16-bit is specified:	0 to 65,535 (upper limit is set up by BFM #3, #2.)									
Comparison Type	Each output is set when the present value of the counter matches with the compare value, and is switched OFF by a reset command. YH: Direct output processed by hardware. YS: Software processed output with worst delay time of 300µs. Therefore, when the input frequency is 50 kHz, there is a worst case delay of 15 input pulses.									
Output signal	Types of outputs <table border="1"> <tr> <td>YH +:</td> <td>transistor output for YH output</td> </tr> <tr> <td>YH -:</td> <td>transistor output for YH output</td> </tr> <tr> <td>YS +:</td> <td>transistor output for YS output</td> </tr> <tr> <td>YS -:</td> <td>transistor output for YS output</td> </tr> </table>	YH +:	transistor output for YH output	YH -:	transistor output for YH output	YS +:	transistor output for YS output	YS -:	transistor output for YS output	
	YH +:	transistor output for YH output								
YH -:	transistor output for YH output									
YS +:	transistor output for YS output									
YS -:	transistor output for YS output									
	Output capacity: 5V ~ 24V DC, 0.5A									
I/O occupation	8 points (can be either inputs or outputs)									

5. Buffer Memories (BFM)

5.1 Buffer memory List

Note;

- When writing in BFM #0 (counter mode), the BFM #1 to #31 will be initialized. After setting the counter mode (BFM #0), other BFM(s) have to be setup. When setting the counter mode, use a TOP (pulsed) instruction, or M8002 (initial pulse) to drive the TO instruction.
- Read/Write of 16 bit data
When using a positive value between K32,768 and K65,535 with 16 bit counters, read/writes of data, such as the current value, ring length, preset data, and the YH/YS compare value, should use the 32-bit forms of the FROM/TO instructions ((D) FROM, (D) TO).

BFM #	Description	Default	BFM Access
BFM #0	Counter mode (Setting range: K0 to K11)	K0	R/W
BFM #1	DOWN/UP command (1-phase 1-input mode (S/W counter) only)	K0	R/W
BFM #2	Ring length	Lower	R/W
BFM #3		Upper	R/W
BFM #4	Command	K0	R/W
BFM #5 ~ #9	Not available	-	-
BFM #10	Preset data	Lower	R/W
BFM #11		Upper	R/W
BFM #12	YH compare value	Lower	R/W
BFM #13		Upper	R/W
BFM #14	YS compare value	Lower	R/W
BFM #15		Upper	R/W
BFM #16 ~ #19	Not available	-	-
BFM #20	Counter current value	Lower	R/W
BFM #21		Upper	R/W
BFM #22	Maximum count value	Lower	R/W
BFM #23		Upper	R/W
BFM #24	Minimum count value	Lower	R/W
BFM #25		Upper	R/W
BFM #26	Compare results	-	R
BFM #27	Terminal status	-	R
BFM #28	Not available	-	-
BFM #29	Error status	-	R
BFM #30	Model identification code: K4010	K4010	R
BFM #31	Not available	-	-

5.2 Details of buffer memories

5.2.1 Counter mode [BFM #0]

The counter mode is shown in the upper right table. (Default value: K0)

Note;

When writing in BFM #0 (counter mode), the BFM #1 to #31 will be initialized. After setting the counter mode (BFM #0), other BFM(s) have to be setup. When setting the counter mode, use a TOP (pulsed) instruction, or M8002 (initial pulse) to drive the TO instruction.

Count modes		32 bits	16 bits	Reference
2-phase input (phase difference pulse)	1 edge count	K0	K1	1), 2)
	2 edge count	K2	K3	1), 3)
	4 edge count	K4	K5	1), 4)
1-phase 2-input (add/subtract pulse)		K6	K7	1), 5)
1-phase 1-input	Hardware UP/DOWN	K8	K9	1), 6)
	Software UP/DOWN	K10	K11	1), 7)

1) 16/32-bit counter modes

a) 32-bit counter modes

(K0, K2, K4, K6, K8, K10)

A 32-bit binary counter which executes UP/DOWN counting will change from the lower limit value to the upper limit value or the upper limit value to the lower limit value when overflow occurs. Both the upper and lower limit values are fixed values: the upper limit value is +2,147,483,647, and the lower limit value is -2,147,483,648.

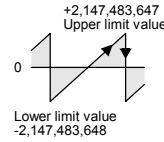

b) 16-bit counter modes

(K1, K3, K5, K7, K9, K11)

A 16-bit binary counter handles only positive values from 0 to 65,535. Changes to zero from the upper limit value or to the upper limit value from zero when overflow occurs; the upper limit value is determined by BFM #3 and #2.

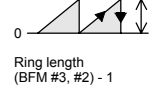

2) 2-phase counter [1 edge-count] (K0, K1)

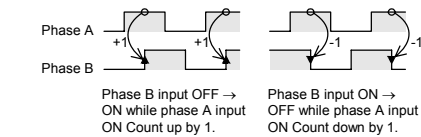

3) 2-phase counter [2 edge-count] (K2, K3)

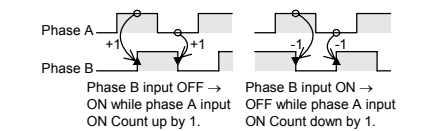

4) 2-phase counter [4 edge-count] (K4, K5)

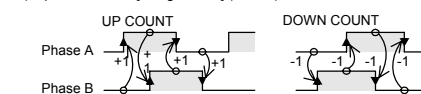

5) 1-phase 2-input counter (K6, K7)

If both phase A and phase B inputs are received simultaneously, the counter value does not change.



6) 1-phase 1-input counter [Hardware UP/DOWN] (K8, K9)

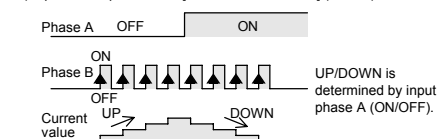

7) 1-phase 1-input counter [Software UP/DOWN] (K10, K11)

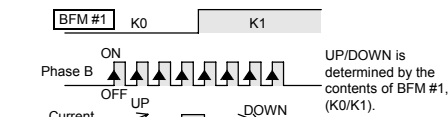

5.2.2 DOWN/UP command [BFM #1]

When using the 1-phase 1-input counter [Software UP/DOWN] (counter mode: K10, K11), set the count direction by the current value of BFM #1. (Default value: K0)
→ For the operation, refer to the Subsection 5.2.1 7)

Count Direction	Setting Value
Up count	K0
Down count	K1

5.2.3 Ring length [BFM #3, #2]

When setting the upper limit value of the 16 bit counters, the setting range is K2 to K65536. (Default value: K65536)
In this example, K100 is written to BFM #3, #2 of special function block No.2 as 32 bit data.

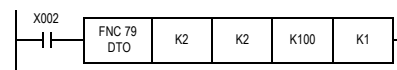

When ring length K100 is specified, the current value of the counter is changed as the right figure, and upper limit value is set to 99.

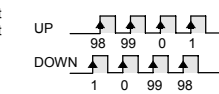

5.2.4 Command [BFM #4]

Bit No.	Setting Value	
	OFF (0)	ON (1)
b0	Count prohibit	Count permit
b1	YH output prohibit	YH output permit
b2	YS output prohibit	YS output permit
b3	YH/YS independent action	Mutual reset action
b4	Preset prohibit	Preset permit
b5 ~ b7	Not available	
b8	No action	Error flag reset
b9	No action	YH output reset
b10	No action	YS output reset
b11	No action	YH output set
b12	No action	YH output set
b13 ~ b15	Not available	

- When b0 is set to ON and the DISABLE input terminal to OFF, the counter is permitted to start counting input pulses.
- Unless b1 is set to ON, YH (hardware compared output) does not turn ON.
- Unless b2 is set to ON, YS (software compared output) does not turn ON.
- When b3=ON, YS output is reset if YH output is set, and YH output is reset if YS output is set. When b3=OFF, YH and YS output act independently, and do not reset each other.
- When b4=OFF, preset function by the PRESET input terminal is disabled.
→ For the preset details, refer to Subsection 5.2.5
- When b8 is set to ON, all error flags are reset.
- When b9 is set to ON, YH output is reset.
- When b10 is set to ON, YS output is reset.
- When b11 is set to ON, YH output is set ON.
- When b12 is set to ON, YS output is set ON.

Example program

The ON/OFF status of M25 to M10 is written in BFM #4 of special function block No.2 by the following program, and b15 to b0 action. Among these, b4 to b0 are always ON as controlled by M10-M14. Furthermore, b8 (M18), b9 (M19), and b10 (M20) are controlled by the input X004 of the PLC, and X005 by ON/OFF.

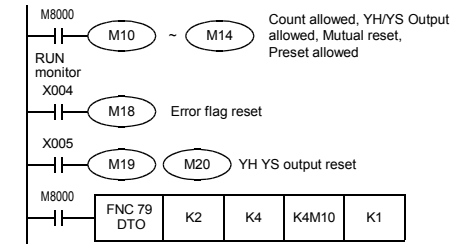

5.2.5 Preset data [BFM #11, #10]

When BFM #4 b4 is ON and the PRESET input is switched from OFF to ON, preset data is stored into BFM #21, #20 (counter current value).
→ For command details, refer to Subsection 5.2.4

5.2.6 YH compare value [BFM #13, #12], YH compare value [BFM #15, #14]

- After comparing the current value of the counter with the value written in BFM #13 and #12, BFM #15 and #14, the hardware and software comparator in the FX2NC-1HC outputs the comparison result.
- YH, YS output will not turn ON if using PRESET or the TO instruction to set the counter value equal to the comparison value. It will turn ON only when a match occurs by the counting of input pulses. However, when BFM #4 b1, b2 are OFF, it does not set.
- Output occurs when the current value becomes equal to the compare value but only if b1 and b2 of BFM #4 are ON. Once an output is set, it remains ON until it is reset by b9 or b10 of BFM #4. If b3 of BFM #4 is ON, however, one of the outputs is reset when the other is set.
- The YS comparison operation takes about 300μs, and if a match occurs, the output goes ON.

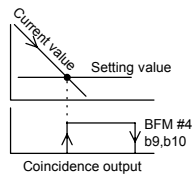
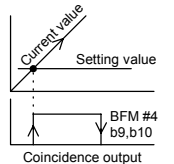

5.2.7 Counter current value [BFM #21, #20]

The current value of the counter can be read by the PLC. It will not be the correct value during high-speed operations because of the communication delay. The current value of the counter can be forcibly changed by writing a 32-bit value into the appropriate BFM's from the PLC.

5.2.8 Maximum count value [BFM #23, #22], Minimum count value [BFM #25, #24]

These store the maximum and minimum value reached by the counter. If the power is turned off, the stored data is cleared.

5.2.9 Compare results [BFM #26]

Bit No.	Target output	OFF (0)	ON (1)
b0	YH	Set value ≤ current value	Set value > current value
b1		Set value ≠ current value	Set value = current value
b2		Set value ≥ current value	Set value < current value
b3	YS	Set value ≤ current value	Set value > current value
b4		Set value ≠ current value	Set value = current value
b5		Set value ≥ current value	Set value < current value
b6 ~ b15	Not available		

5.2.10 Terminal status [BFM #27]

Bit NO.	Signal Name	OFF (0)	ON (1)
b0	PRESET input	OFF	ON
b1	DISABLE input	OFF	ON
b2	YH output	OFF	ON
b 3	YS output	OFF	ON
b 4 ~ b15	Not available		

5.2.11 Error status [BFM #29]

Bit NO.	Error Status	
b0	Set when any of b1 to b7 is ON.	
b1	Set when the value of the ring length is written incorrectly. (Except K2 to K65,536)	
b2	Set when the preset value is written incorrectly.	When value ≥ ring length in 16-bit counter mode.
b3	Set when the compare value is written incorrectly.	
b4	Set when the current value is written in correctly.	When the upper or lower limit is exceeded on a 32-bit counter.
b5	Set when the counter overflows the upper limit.	
b6	Set when the counter overflows the lower limit.	
b7	Set when the FROM/TO command is used incorrectly.	
b8	Set when the counter mode (BFM#0) is written incorrectly.	Except K0 to K11
b9	Set when the BFM number is written incorrectly.	Except K0 to K31
b10 ~ b15	Not available	

Error status in the FX2NC-1HC can be checked by reading the contents of b0 to b9 of BFM #29 to auxiliary relays of the PLC.
There error flags can be reset by b8 of BFM #4.



5.2.12 Model identification code [BFM #30]

This BFM stores the identification number for FX2NC-1HC. The identification number for the FX2N-1HC unit is K4010. By reading this identification number, the user may create built-in checking routines to check whether the physical position of the FX2NC-1HC matches that of the software.

6. Example Program

Please use the following program as a guide whenever you use the FX2NC-1HC unit. Other instructions to read the current value of the counter, status etc. can be added as required.

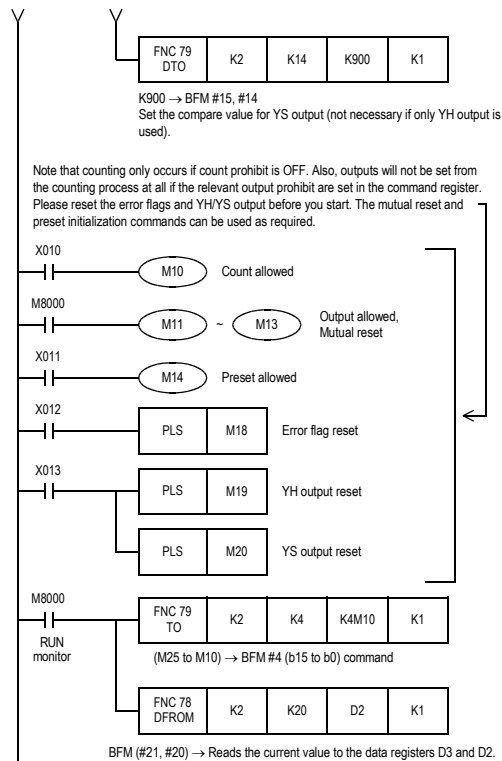
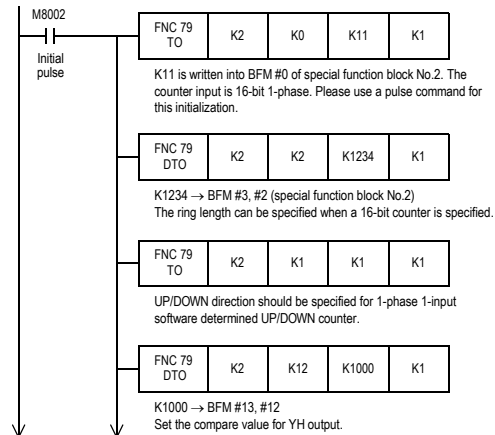

7. Preliminary checks

- Check that the I/O wiring and extension cable of the FX2NC-1HC are properly connected.
- The FX2NC-1HC occupies 8 points of I/O on the FX2NC, FX3UC expansion bus. The 8 points can be allocated from either inputs or outputs. 5V DC 90mA power is supplied from the main or extension power supply units (FX3UC only) for the FX2NC-1HC. Check that there is no power overload from this and other extension blocks.
- The following derating curve shows the simultaneous ON ratio of available power for products connected to the FX2NC-1HC with respect to the ambient temperature. Use the adjoining following product within the simultaneous input ON ratio range shown in the figure.
Target input extension block: FX2NC-16EX, FX2NC-16EX-DS, FX2NC-32EX, FX2NC-32EX-DS

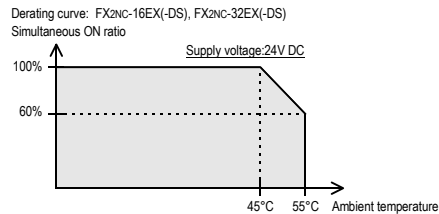

- The counter works correctly only when data such as the counter mode (set with a pulse command), the TO command, the compare value, etc. are appropriately specified. Remember to initialize the count (BFM #4 b0), preset (BFM #4 b4), and output (BFM #4 b2, b1) prohibits. Reset the YH/YS outputs before you start.

Note

Note that inputting the pulse higher than the maximum frequency may cause mis-counting to FX2NC-1HC or a FROM/TO error to the PLC main unit.

8. Diagnostics

STARTUP AND MAINTENANCE PRECAUTIONS **CAUTION**

- Do not disassemble or modify the PLC. Doing so may cause fire, equipment failures, or malfunctions.
 - For repair, contact your local Mitsubishi Electric distributor.
- Do not drop the product or exert strong impact to it. Doing so may cause damage.

DISPOSAL PRECAUTIONS **CAUTION**

- Please contact a certified electronic waste disposal company for the environmentally safe recycling and disposal of your device.

TRANSPORT AND STORAGE PRECAUTIONS **CAUTION**

- The product is a precision instrument. During transportation, avoid any impacts. Failure to do so may cause failures in the product. After transportation, verify the operations of the product.

- The following LEDs on the main panel of the FX2NC-1HC may help you to troubleshoot the unit.
 - φA, φB: Goes on/off as φA, φB input turn ON/OFF. It can be checked by rotating the encoder slowly.
 - UP, DN: Lights up to indicate whether the counter is going up (UP) or down (DN).
 - PR, DS: The appropriate LED lights up when the PRESET (PR) terminal or the DISABLE (DS) terminal is ON.
 - YH, YS: The appropriate LED lights up when YH/YS output is turned on.
- You can check the error status by reading the content of BFM #29 to the PLC. → For error contents, refer to the Subsection 5.2.11

9. System Block Diagram

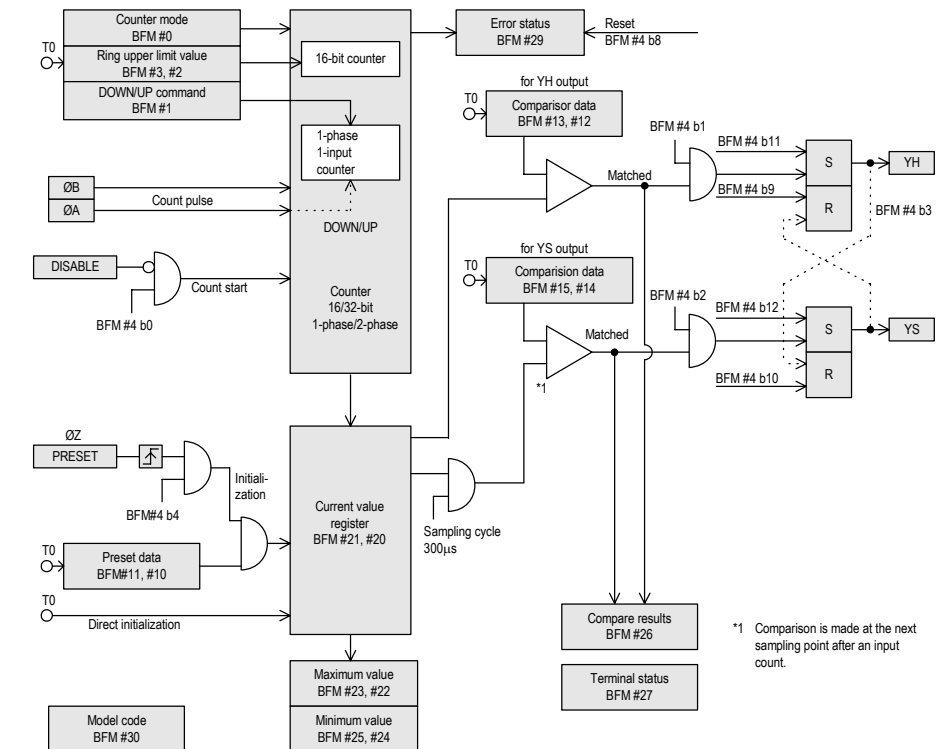

*1 Comparison is made at the next sampling point after an input count.

This manual confers no industrial property rights or any rights of any other kind, nor does it confer any patent licenses. Mitsubishi Electric Corporation cannot be held responsible for any problems involving industrial property rights which may occur as a result of using the contents noted in this manual.

Warranty

Mitsubishi will not be held liable for damage caused by factors found not to be the cause of Mitsubishi; opportunity loss or lost profits caused by faults in the Mitsubishi products; damage, secondary damage, accident compensation caused by special factors unpredictable by Mitsubishi; damages to products other than Mitsubishi products; and to other duties.

For safe use

- This product has been manufactured as a general-purpose part for general industries, and has not been designed or manufactured to be incorporated in a device or system used in purposes related to human life.
- Before using the product for special purposes such as nuclear power, electric power, aerospace, medicine or passenger movement vehicles, consult with Mitsubishi Electric.
- This product has been manufactured under strict quality control. However when installing the product where major accidents or losses could occur if the product fails, install appropriate backup or failsafe functions in the system.

MITSUBISHI ELECTRIC CORPORATION

HEAD OFFICE : TOKYO BUILDING, 2-7-3 MARUNOUCHI, CHIYODA-KU, TOKYO 100-8310, JAPAN

